

K-1000C Operation manual



一、K-1000C system features

- 1、32 to 65536 grade gray control, software Gamma correction processing.
- 2、Supports various point, line and area light sources, supports various rules, and special-shaped processing.
- 3、The single port output of the controller can reach a maximum of 512/2048 pixels (the maximum 512 pixels of the DMX luminaire is exemplified by three channels).
- 4、The playback content is stored in the SD card, which can store up to 32 effect files. The SD card capacity supports 128MB-32GB.
- 5、The controller can be used in a single unit or in multiple cascades. The cascade uses photoelectric isolation: anti-interference and better stability. The cascade distance between the two units can reach 150 meters, and 0.5 square meters of pure copper power cord is needed.
- 6、The controller with the loaded chip can lock the loaded IC in the software or not. By adjusting the controller's chip button to select the loaded IC, this scheme is more flexible and convenient.
- 7、The IC controller for DMX luminaires comes with a write address function; in addition, with our 2016 LedEdit-K V3.26 or higher software, one-click address function can be set.
- 8、Supports on-board luminaires with 4 channel (RGBW) pixels or split into single channel point pixels.
- 9、Enhanced TTL and 485 differential (DMX) signal output.
- 10、The controller comes with 22 test effects and comes with DMX512 test function.

Remarks: 1. The controller carries 512 pixels of light, the speed can reach 30 frames/second, the speed of 1024 pixels can reach 25 frames/second, and the speed of 2048 pixels is about 15 frames/second (the above parameters are based on the 1903 protocol IC DATE, there will be differences between different IC).

2. The international standard DMX512 (1990 protocol) has a maximum load of 512 pixels. When the load is 170 pixels of the international standard, the speed can reach 30 frames/second, the speed of 340 points is about 20 frames/second, and the speed of 512 pixels is about 12 frames/second.

3. For the function of Beidou wireless synchronization, please contact sales staff or technical support for details.

二、Support chips:(PC software selects K-1000-RGB):

- 00: UCS19**,UCS29** ; TM18**,SM167**,WS28**,GS82** ; SK6812 (Support max.2048 pixels)
- 01: SM16716,16726(Support max.2048 pixels)
- 02: P9813 (Support max.2048 pixels)
- 03: LPD6803 (Support max.2048 pixels)
- 04: LX1003,1203(Support max.2048 pixels)
- 05: WS2801(Support max.2048 pixels)
- 06: LPD1886(Support max.2048 pixels)
- 07: TM1913(Support max.2048 pixels)
- 08: TM1914(Support max.2048 pixels)
- 09: P9883,P9823(Support max.2048 pixels)
- 10: DMX (250kbps max. spooort 512 pixels, suggest to support ≤ 320 pixels)
- 11: DMX 500K(500kbps max. spooort 512 pixels, suggest to support ≤ 320 pixels)
- 12: DMX 250K-CZF (max. spooort 512 pixels, suggest to support ≤ 320 pixels)
- 13: DMX 500K-CZF (max. spooort 512 pixels, suggest to support ≤ 320 pixels)
- 14: UCS5603-Test (Support max.2048 pixels)
- 15: UCS5603A(Support max.2048 pixels)
- 16: UCS5603B(Support max.2048 pixels)
- 17: TM1814(Support max.2048 pixels)
- 18: INK1003(Support max.2048 pixels)
- 19: APA102(Support max.2048 pixels)
- 20: UCS8904(Support max.2048 pixels)
- 21: SM16714(Support max.2048 pixels)
- 22: SM16813(Support max.2048 pixels)
- 23: GS8512 (max. spooort 512 pixels, suggest to support ≤ 320 pixels)
- 24: QED3110 (Support max.2048 pixels)

Remarks: 1. For RGBW four-channel luminaires need to select K-1000-RGBW, and above four-channel luminaires needs to select K-1000-RGBWYA.

2. The K-1000-W is required when carry the single-channel luminaire. In this case, one channel represents one pixel, and the software effect is white.

三、Appearance picture:



四、Silk screen definition:

1. Button meanings:







Button	Definition	
CHIP	Switch the chips	Press the chip button and then press the mode button to enter the code writing mode; after completing the code writing, press the chip button and then press the mode button to exit the writing mode.
MODE	Switch the files	
SPEED+	Speed up	Press SPEED+ and SPEED- at the same time to enter the effect file loop playback mode, and the display C C C flashes, indicating that entered the file loop playback mode
SPEED-	Speed down	

2. Port definition:

DC 5-24V	DC 5-24V power positive input	IN A	Cascaded synchronization signal, connect the previous OUT A
GND	DC power supply negative input	IN B	Cascaded synchronization signal, connect the previous OUT B
POWER	Power indicator	OUT A	Cascaded synchronization signal, connect the next IN A

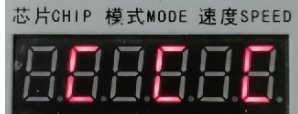
ERROR	Status indicator	OUT B	Cascaded synchronization signal, connect the next IN B
SD card	SD card slot		
GND	Ground line(negative)	B	Signal - (DAT-)
CLK	Clock line (DMX lights address writing)	A	Signal + (DAT+)
DAT	DATA line		

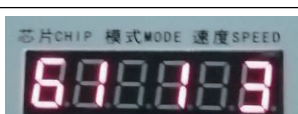
3. Display vocabulary (six digit screen)

Display		Definition
1	 <p>芯片CHIP 模式MODE 速度SPEED F F F F F F</p>	F_F_F Card reading error
2	 <p>芯片CHIP 模式MODE 速度SPEED A A A A A A</p>	A_A_A DMX512 write address
3	 <p>芯片CHIP 模式MODE 速度SPEED C C C C C C</p>	C_C_C Effect loop playback
4	 <p>芯片CHIP 模式MODE 速度SPEED 2 2 2 2 2 2</p>	2_2_2 Cascaded control
5	 <p>芯片CHIP 模式MODE 速度SPEED 0 0 0 0 0 0</p>	0_0_0 Enter DMX lamp address test / parameter write
6	 <p>芯片CHIP 模式MODE 速度SPEED 6 1 1 1 1 1</p>	Write code interface Chip display: DMX512IC code 61-80 Mode display: No definition Speed bit: Number of channels 0-99
7	 <p>芯片CHIP 模式MODE 速度SPEED 0 0 0 0 0 0</p>	Play interface Chip display: onboard IC code 0-23 Mode display: Program serial number Speed: 1-16 level

4. Speed grade corresponding to frame rate:

Speed	Frame/second	Speed	Frame/second	Speed	Frame/second	Speed	Frame/second
1	4 Frame	5	8 Frame	9	14 Frame	13	23 Frame
2	5 Frame	6	9 Frame	10	16 Frame	14	25 Frame
3	6 Frame	7	10 Frame	11	18 Frame	15	27 Frame
4	7 Frame	8	12 Frame	12	20 Frame	16	30 Frame

五、Conventional IC lamp wiring DAT/CLK/GND

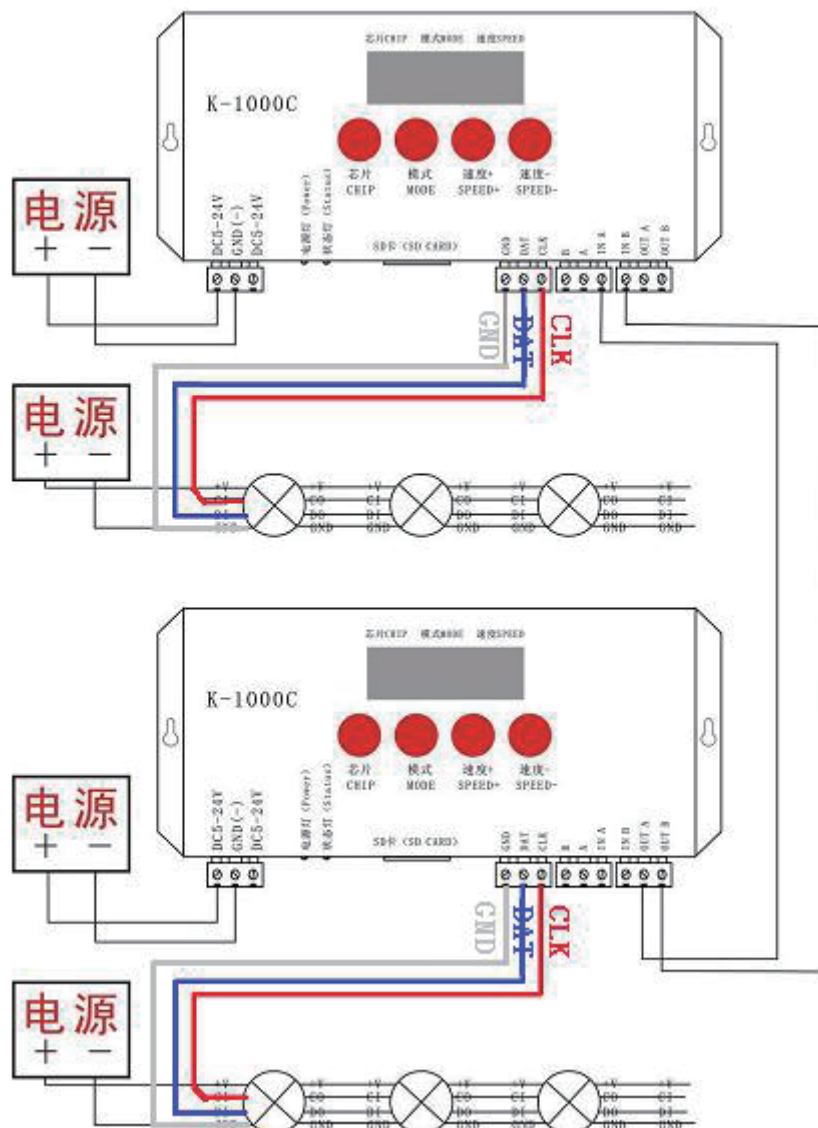

六、DMX512 luminaire wiring method:

DMX512 differential signal line wiring diagram: **A/B/ADD/GND (A/B/GND)**

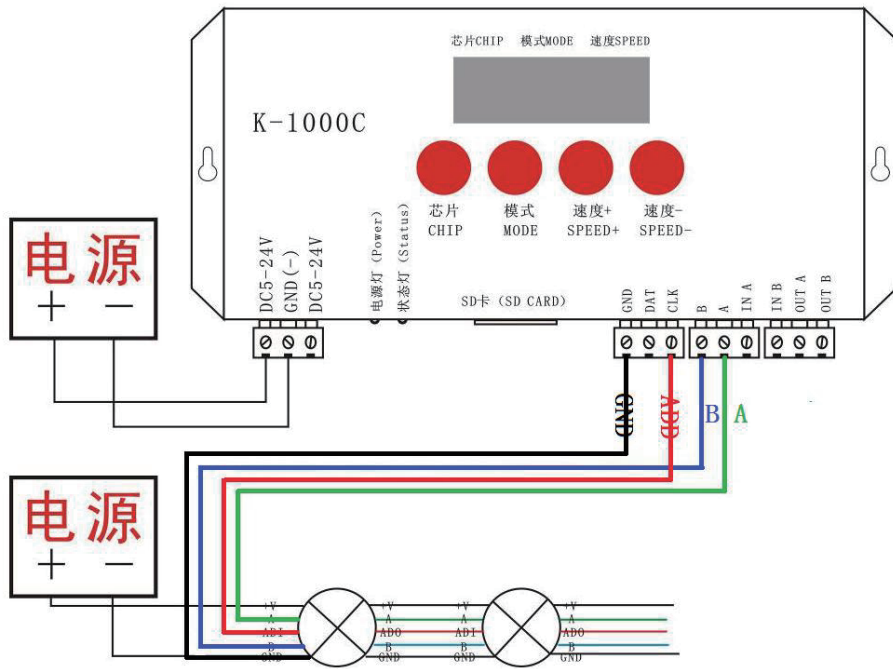

DMX512 single line signal wiring diagram: **A(DAT)/ADD/GND**

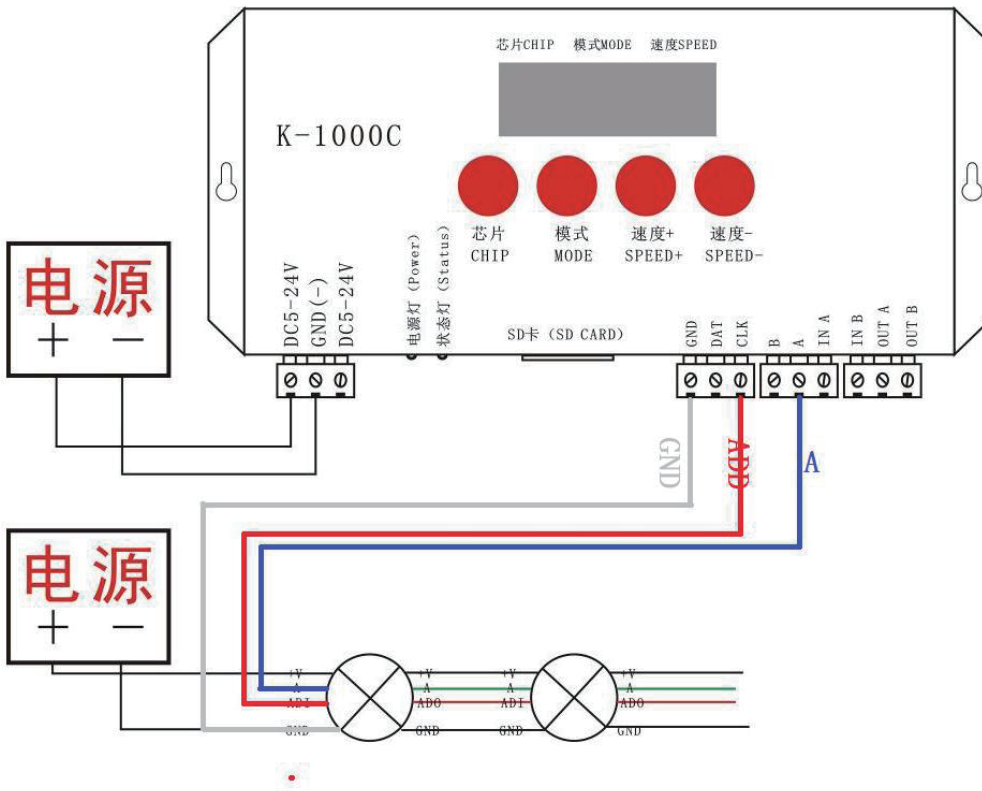

Note: For some DMX512 luminaire installations, the controller output terminal does not need to be connected to the ADDR write address line of the luminaire. It only needs to be connected to A/B/GND, and its data bus is automatically addressed (for details can refer to the DMX512 luminaire loaded IC usage

specification).

七、DMX512 lamp writing code and lamp address test

1. Connect the line as shown above to start the controller. First press and hold "Chip CHIP" and then press the "Mode MODE" button to switch to the address mode, as shown below: "61_*_3",



2. Press the "Chip CHIP" button to select the DMX512 onboard IC model; "Speed+" and "Speed-" select the fixture interval channel (0-99).

DMX512IC code as the below list:

Appendix: DMX512IC code and IC correspondence table			
61: UCS512A*/B*,TM512AL1/AB	62: WS2821	63: SM DMX512AP-N	64: UCS512C*,TM512AC*
65: SM1651*-3CH	66: SM1651*-4CH	67: UCS512D*/TM512AD*	68: UCS512E*
69: UCS512E (Chip parameter setting)	70: SM17512*	71: SM17522*	72: UCS512-F
73: TM512AC*	74: SM17500 regular address writing	75: SM17500 chip itself parameter setting	76: SM17500 chip parameter setting and then address writing
77: GS8512 regular address writing	78: GS8512 write single address	79: GS8512 set as no address	80: QED512P

NOTE 1: 69 is the chip itself parameter setting for UCS512E* lights, and apply it to the load IC of UCS512E*. Step 1: select 69 and write the chip itself parameter to the same specification lights; Step 2, select 68 to write address for the lights.

NOTE 2: 75: It is the chip itself parameter setting for SM17500 lights, and apply it to the load IC of SM17500. Step 1: select 75 and write the chip itself parameter to the same specification lights; Step 2, select 76 to write address for the lights.

NOTE 3: 78: GS8512 write single address, and apply to the load IC of GS8512, at the same time to write the same address code for multiple lights.

NOTE 4: 79: GS8512 set as no address mode, apply to the load IC of GS8512, Set it to use in serial (TTL/SPI) mode.

3. After selecting the code, press "MODE MODE" to write code. At this time, the screen will display A A A. The

following picture is displayed:



4. After writing the address code, the controller enters the DMX512 lamp channel test mode: the digital screen displays A 0000;



5. Press the “MODE MODE” button to enter the automatic test mode, the display is “A *****” (* is the number of channels), and the fixture will automatically start the white light from the first pixel.

6. Press the “MODE MODE” button again to enter the manual test mode, the display is “C *****” (* is the number of channels), “Speed +” and “Speed -” can adjust the pixel points (long press “Speed +” or “Speed -” can be quickly incremented or decremented”, the lighting pixels are lit one by one;



7. After the test is completed, press "CHIP" to exit the channel test and return to the write code interface;



8. Press and hold "Chip CHIP" first, then press the "Mode MODE" button to switch to playback mode and switch the chip to Chip: 10, it is the DMX512 standard protocol 250Kbps playback mode. At this time, press the mode button and the speed button to switch the playback mode and adjust the speed respectively, as shown below:



八、DMX512 light one-button address writing

1. When the software writes the program output, click the button to enter the one-click address interface.

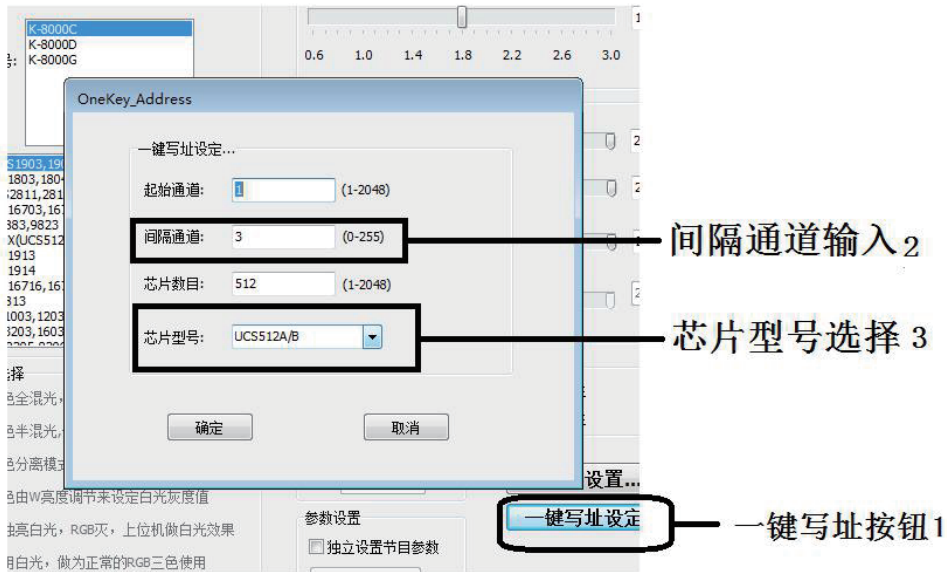

2. Interval channel input

The interval channel is input according to the actual value of the luminaire. The value is the number of channels occupied by a DMX512 IC to control the pixel points of the luminaire.

3. Chips mode selection

Click the drop-down button to select the chip model corresponding to the DMX512 IC on the lamp.

4. Complete the one-button address writing setting

Confirm the settings are correct, click the confirm button to complete the program output.

5. Controller one-click address writing operation

① SD card inserted into the controller;

② Power on the controller;

③ Long press "MODE" button for 5 seconds, the controller display "A-A-A" means it is writing address now;

④ After the address is written, the controller will also enter the channel test mode (same as the channel test after manual address).

⑤ After completing the channel test, press the "chip chip" button to exit the test mode, and the controller returns to the playback mode to work normally.

九、DMX512 luminaire test

1. Press the "Speed -" button to power on, enter the lighting test interface, display 0 0 0



2. It takes about 2 seconds to enter the test fixture address interface without any operation. The controller displays A3 0000.

3. Press the “MODE” button to start the automatic test of the lamp address.

Appendix: Display vocabulary definition list				
Automatic mode	Definition	Mnual mode	definition	
A 1 ****	1 channel automatic test	C1 ****	1 channel manual test	
A 2 ****	2 channel automatic test	C2 ****	2 channel manual test	
A 3 ****	3 channel automatic test	C3 ****	3 channel manual test	
A 4 ****	4 channel automatic test	C4 ****	4 channel manual test	

NOTE 1: The first digital tube indicates the automatic and manual test mode: A is the automatic test mode, C is the manual test mode, and is switched by the "CHIP" key;

NOTE 2: The second digital tube represents the pixel point channel of the luminaire, 1 is a monochrome single-channel luminaire, 2 is a two-color two-channel luminaire, 3 is an RGB three-color luminaire, and 4 is an RGBW four-color luminaire, which is switched by a “mode MODE” key;

NOTE 3: The 4th-6th digit tube indicates the number of the lights.

4. After the test is powered off and restarted, the controller can enter the normal play mode.

十、 Specific parameters:

Physical parameters:

Working temperature: -30°C—85°C

Working power supply: DC 5V -24V input

Memory card:

Type: SD card

Capacity: 128MB-32GB

Power consumption: 2W

Format: FAT or FAT32 format

Data transmission port: 3pin terminal block

Storage file: *.led

Weight: 0.35Kg

Size:

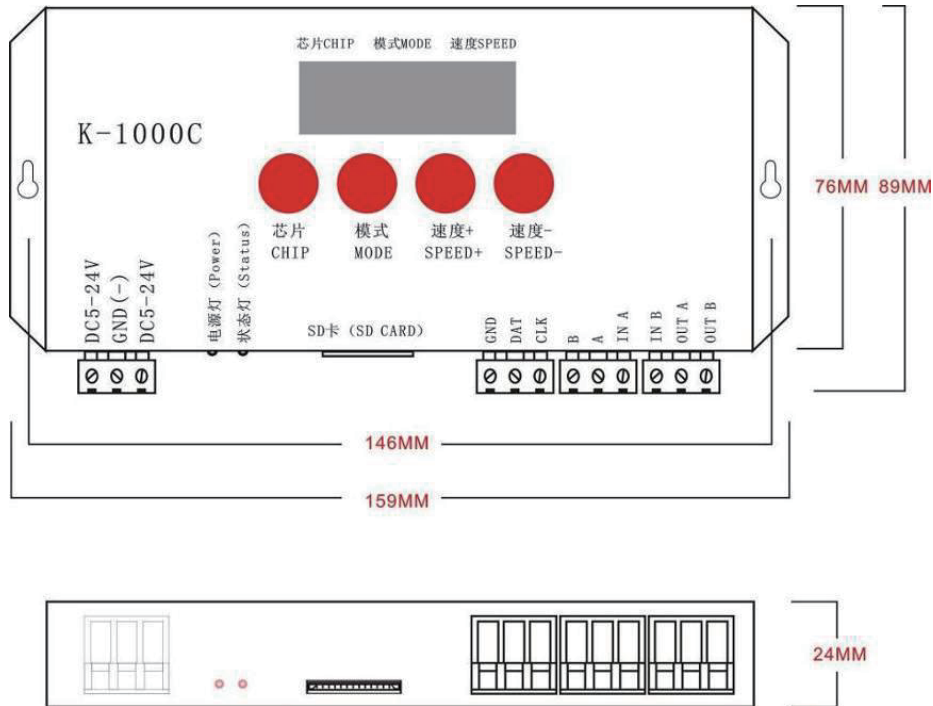

十一、SD card formatting

1、The SD card must be formatted before copying the file to the SD card (note that it is formatted before each copy).

2、Formatting process

①SD card settings - "File System", "FAT" format (SD card capacity \leq 2G) or "FAT32" format (SD card capacity \geq 4G).

②SD Card Settings - "Assign Unit Size", click the drop down button to select "Default Configuration Size" or click the "Restore Device Defaults" button.

③Start formatting.

As shown below:



3、The SD card cannot be hot swapped, that is, the power of the controller must be disconnected each time the SD card is inserted or removed.

Common problem handling:

Question 1: After power-on, the controller screen is displayed as F F F and there is no effect output.

A: The screen displays FFF indicating that the controller is not reading the card correctly. Possible problems are:

- ①SD card is empty, no effect file.
- ②SD card inside the effect file *.led file and controller model does not match, please select the controller model, chip model in the latest version 2016LedEdit, and re-create the effect file *.led.
- ③After replacing the SD card, test it again to eliminate the possibility of SD card failure.

Question 2: After power-on, the controller outputs the built-in effect, no SD card effect playback

A: The controller can not detect the SD card and automatically plays the built-in program:

- ①The controller does not insert an SD card and inserts an SD card.
- ②The card has been inserted, the SD card is not inserted in place, and the SD card is reinserted.
- ③The card has been inserted, the controller does not match the SD card, the SD card is not detected, and the matching SD card is replaced.

Question 3: After the controller is powered on, the indicator light is normal, but the lamp has no effect change.

A: The reasons for this situation are as follows:

- ①Please check if the signal line of the luminaire and the controller are connected correctly.
- ②The signals of conventional luminaires are divided into in and out, and it is determined whether the control is a signal connecting the first luminaire.

Question 4: After the controller is connected to the luminaire, the strobe flashes and the effect changes, and the controller indicator shows normal.

- A: ①The ground wire between the controller and the luminaire is not connected.
- ②The effect done in the SD card is incorrect. The lamp chip selected when the effect is made does not match the chip of the actual lamp.
- ③ When editing effects on the software but did not lock the chip, the chip of the controller should be attached to the corresponding chip of the luminaire. Refer specifically to the IC sequence of the sticker on the controller.
- ④The power supply voltage of the luminaire is insufficient.

Question 5: The SD card cannot be formatted.

- A: : ①First confirm that the protection switch on the side of the SD card has been unlocked. The direction of unlocking is the end of the SD card gold needle.
- ②The protection lock has been designed as required, but it still cannot be formatted. If this happens, most of the SD card readers are broken. Please replace the SD card reader (suggest to use a better quality card reader like SSK (Biao wang) card reader).
- ③If the above operations cannot solve the formatting problem, please replace the SD card and retest.